

36"

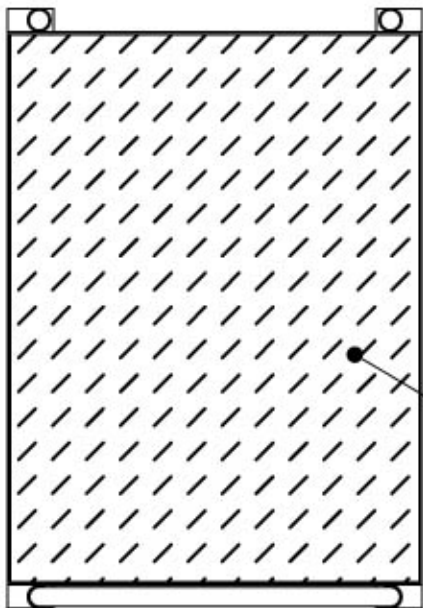

48"

Plaque striée

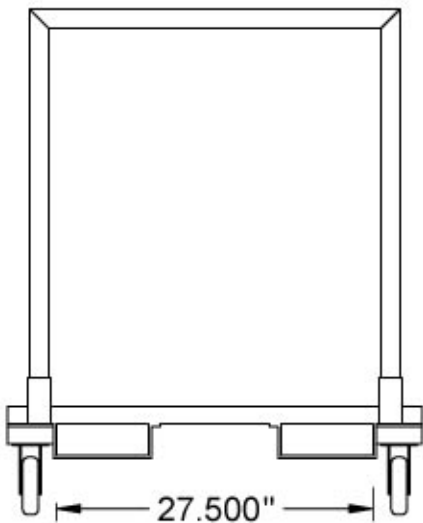
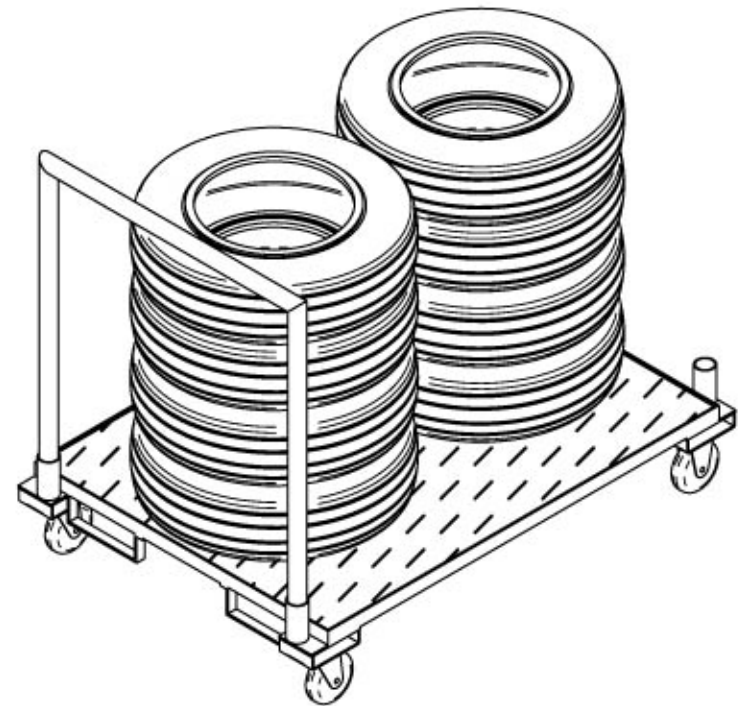

27.500"

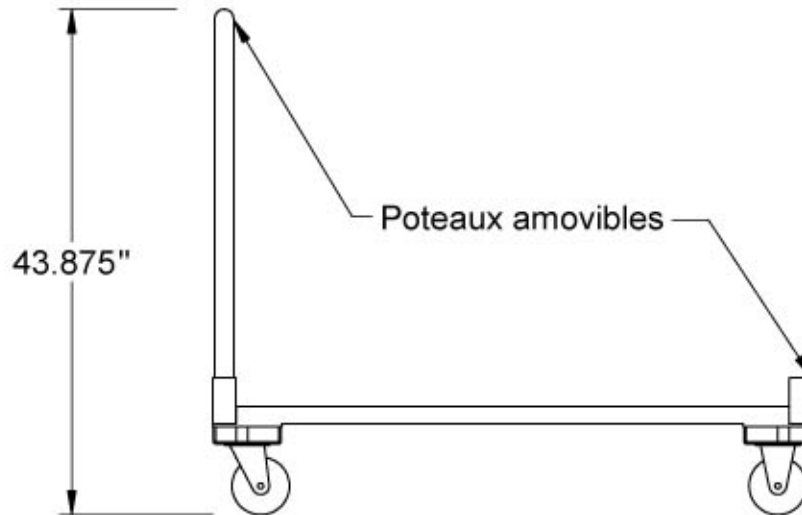

43.875"

Poteaux amovibles

MARTINS
INDUSTRIES

1-866-406-RACK

WWW.MARTINSINDUSTRIES.COM

Modèle: Chariot de commande

Poids: 165 lbs

Qté. pneus: -----

Qté.(vrac): -----

Dim. max: 44" O.D.

Capacité: 2000 lbs

Empilable ouvert: -----

Empilable fermé: -----